

# Product Specifications

## LED-CON2 RGB DMX Controller



**sirs-e**  
[www.sirs-e.com](http://www.sirs-e.com)

**High Power DMX Decoder & driver**

**Model: LED-CON2**

Meets DMX512/1990

Can drive 5A (Each CH.)

Can drive many kinds of LED lamps

PRODUCT SPECIFICATION

Updated at 2006-10-9

## SUMMARIZE

Thank you for using LED-CON2 series decoder with advanced micro-computer control technology. PX series convert the widely used DMX512/1990 signal to analog signal and can choose 1~3 output channel, 256-level brightness control. Can be use for connecting of light console and analog device, or lighting & building lamps controlling.

## FEATURES

- Meets DMX512/1990
- 256-level brightness, full-color control
- 3 output CH., can drive 5A (Each CH.)
- With control system, can express perfect effect
- Can drive 1~3 channel of each lamp
- Can set the DMX address freely
- Modularizing, can be combined with LED module neatly
- Can be custom-made

## TECH. CHARACTERISTICS

- Decode CH.: 1~3
- Input Signal: DMX-512/1990 digital signal
- Output Signal: 0~24V PWM signal, can drive 5A(Each CH.)
- Power Supply: DC, +12~25V
- Power Dis.: <1W
- Power Output: 180W/12VDC 240W/24VDC
- Operating Temp.: 0~70°C
- Size: 175(mm)\*45(mm)\*35(mm), can be custom-made
- Weight: ≤300g

## DIMENSION Appearance

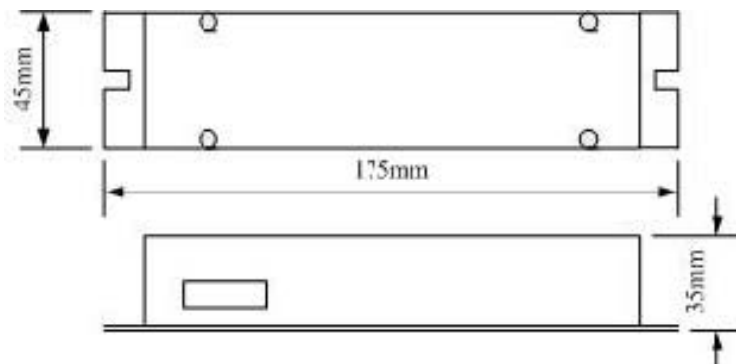

**Internal Block Diagram**

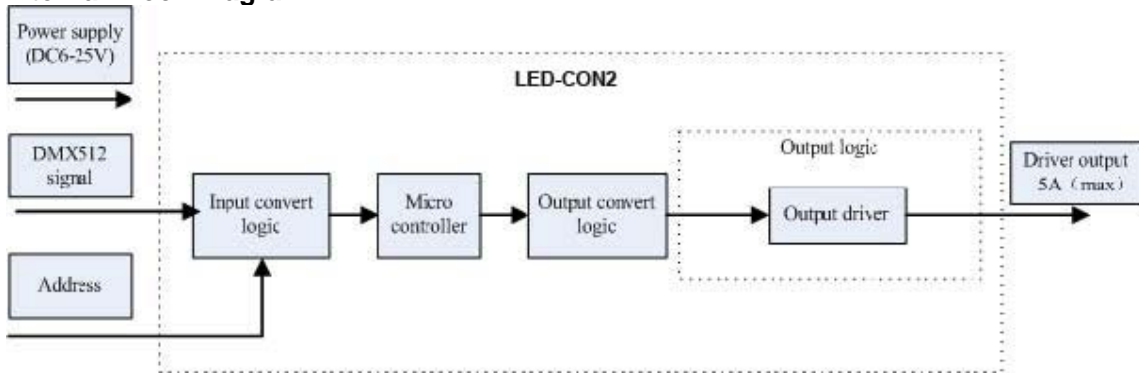

**Appearance**



- (1) DMX signal input interface(RJ45)
- (2) DMX signal output interface(RJ45)
- (3) Address setting interface
- (4) Driver output interface
- (5) Power input interface

**Interface Introduction**

- DMX signal interface

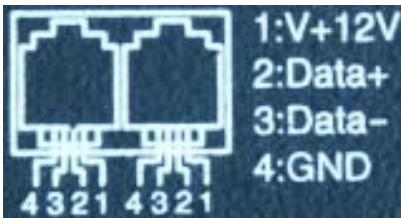

- Address setting interface  
Please find the detailed instruction for Address setting at Page 5.
- Power input interface  
DC 12-25V input, supply power for decoder and the lamps it takes.
- Driver output interface  
Common anode, V+ and R,G,B interface can drive kinds of RGB module or single-color module. It can regulate output current according to the actual load.

**Remark:**

Connect the anode and RGB wire of common anode RGB module to the output interface of decoder directly; Connect the anode wire of single-color module to V+ on decoder, and connect the cathode wire to one of RGB pin according to the LED's color; Connect several colors single-color module to one decoder, please connect their anode wires to V+ pin on decoder.

**How To Use**

LED-CON2 is controlled by DMX-512 digital signal. The frontage is DMX512 transmitter, take decoder for example, to control 0~24V analog devices. We suppose to drive LED to introduce it. The connecting is below:

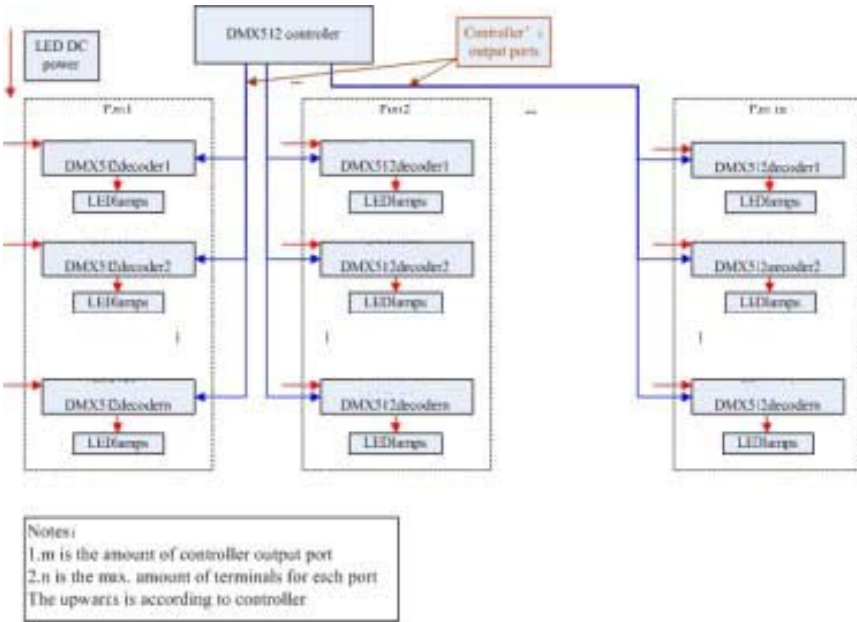

**TYPICAL APPLICATIONS**

◆ Circuit Diagram 1

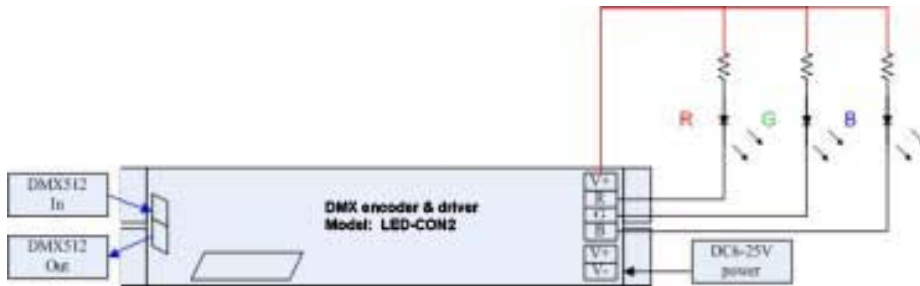

**Connecting of DMX-512 Signal**

- ◆ The wire for DMX signal is STP, the DMX signal has positive and negative signal. Pay attention to the polarity while soldering. Connect the positive signal, negative signal and GND to the corresponding signal of LED-CON2.
- ◆ Connect a signal terminal at the end of the whole connection.

**Calculate the power**

This product has a wide input/output voltage (DC 6-25V) and it's rating current is 5A. The rating power is different at the input. For example:

Rating power in 12V: **180 W**

Rating power in 24V: **360 W**

**DMX-512 Address Setting**

The DIP switch on LED-CON2 can set the binary value of the DMX512 address to receive data. The correlative bits is the 1-9 bits of the DIP switch, the 1st bit is LSB, the 9th bit MSB 512 addresses totally. The start address is the no. of the first channel of the decoder, the second channel will receive the data of start address+1, and the third channel will receive the data of start address+2. There are two way to find out the relation between the DIP switch and DMX address.

**Calculation method:**

Calculation formula: [the sum of 1~9 bit of the DIP switch] + 1 = DMX start address Set the n(th) bit of the DIP switch up (set to“1”) to get the value of such bit; Set the n(th) bit of the DIP switch down “0”) , so the value of this bit is 0.Note: the 10th bit is not use.

**Value of each DIP:**

DIP	1	2	3	4	6	7	8	9
Value	1	2	4	8	32	64	128	256



**Example 1: Set to 38**

Set the 6th,3rd,1st bit of the DIP switch to“1”, others set to“0”, then the sum of the 1~9 is 32+4+1, then add 1 to it, is the start address 38.

That is: [ 32 + 4 + 1 ] + 1 = 38

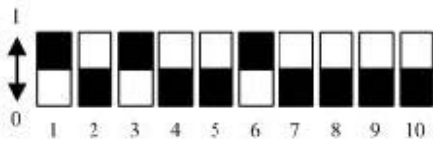

**Example 2: Set to 226**

Set the 8th, 7th, 6th, 1st bit to “1”, others set to“0”, then the sum of the 1~9 is 128+64+32+1, then add 1 to it, is the start address 226.

That is: [ 128 + 64 + 32 + 1 ] + 1 = 226

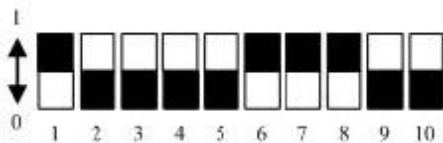

The contents about the product install and usage

Principle:

- (1)The input voltage should be limited in rated range.
- (2)Do not use it by over load.
- (3)Install it in a suitable environment.

- A. The driver can not be setting in high temperature or wet conditions
- B. We recommend three ways to take away the heat as follows ①Bared in moving air ②Put in a big enough space for taking away the heat ③Fixed on big metallic board, and make sure they are contacted well

The contents about install and usage

- (1)When work with controller, put the controller close to avoid the signal become weak.
- (2)Recommend to use the STP with the characteristic impedance of 120 ohm
- (3)The signal line should be one bus, and the signal line pass in and out the decoder ports directly
- (4)Make sure the signal line connector and the decoder's signal port are well connect
- (5)Add a signal terminator at the end of the signal line
- (6)The decoder should be closed to the lamps. If the lamps is over 5 meters, the ones follow shoule be joined at the decoder's out port again
- (7)Adopt thicker power cable with good conductivity
- (8)If one decoder take several lamps in series, make sure the lamps' connectors are firmly connected
- (9)Signal line should be far away with the 110/220V AC cable

Install Cases:

(In the attached drawing, the unconscionable of install cases were labeled by "X")

(1)The bad install manners of take away the heat and the right ways:

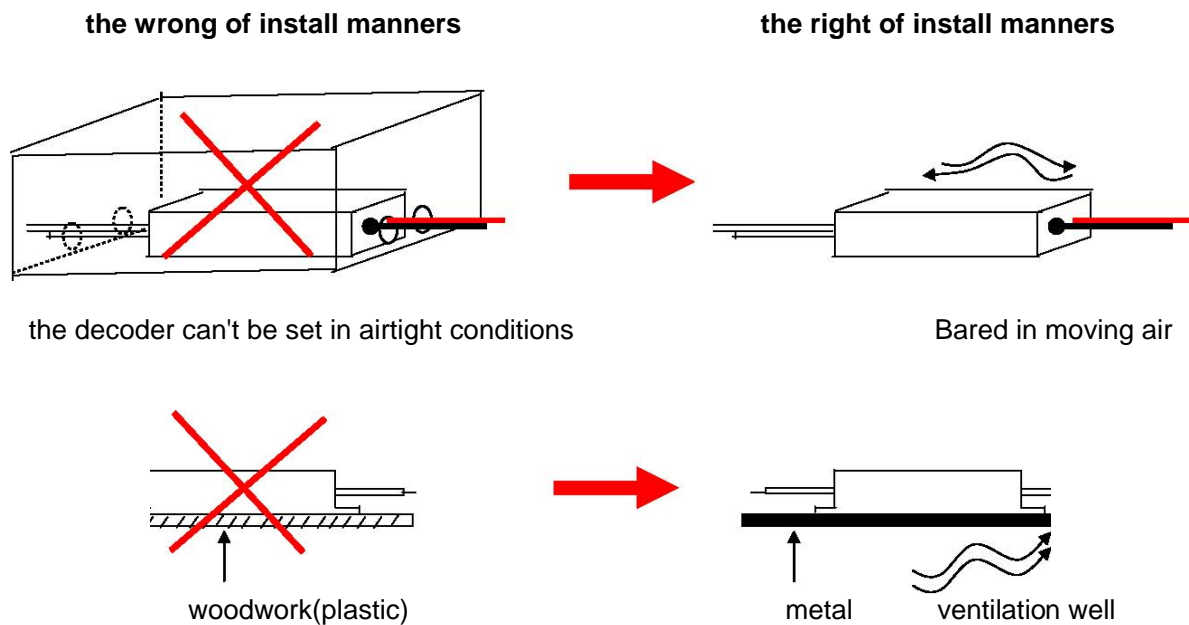

(2)The install manners with weak signal and the right ways:

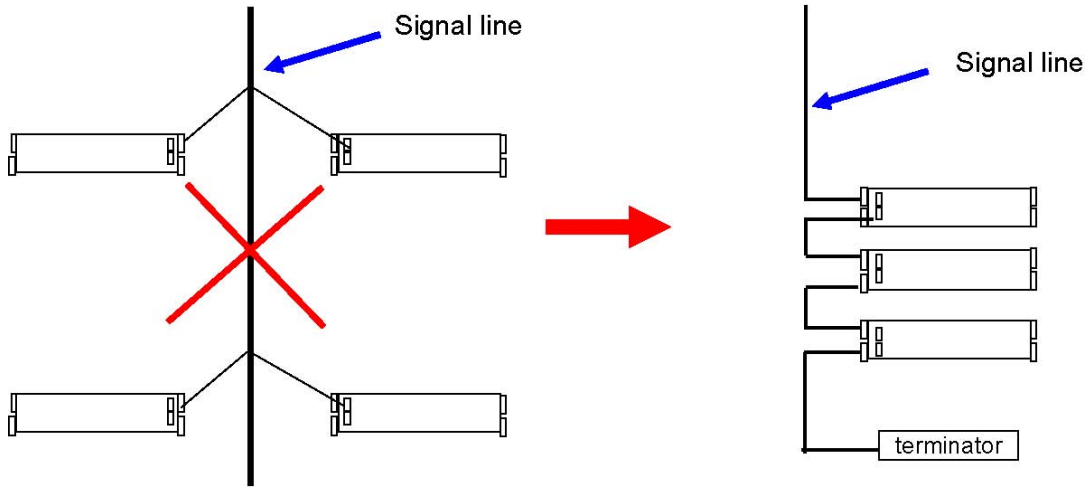

signal line was linked side by side

The signal line should be one bus and add a the signal terminator at the end of it

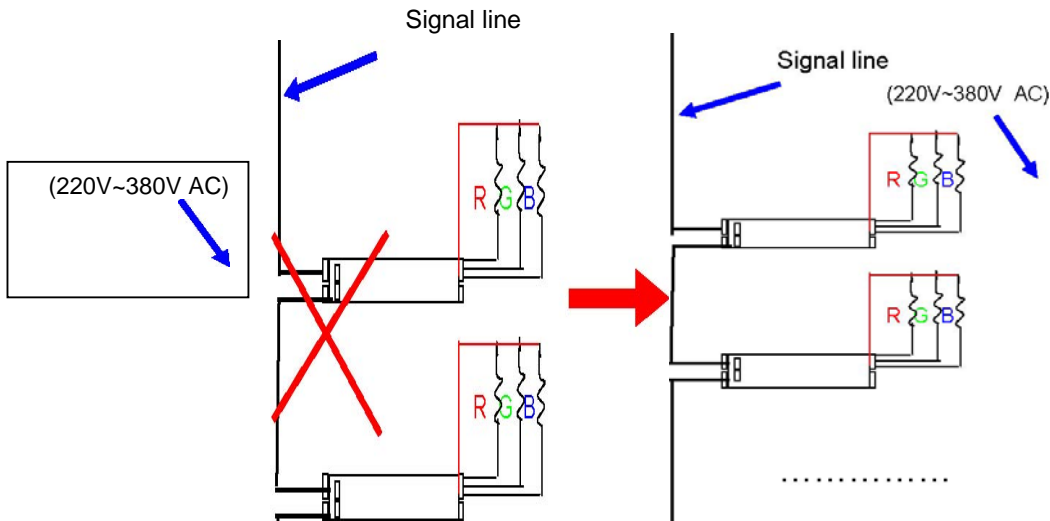

Signal line was closed to the 220/380V AC

Signal line should be far away with the 220/380V AC

Troubleshooting Guide

Problem	Reason	Solution
1.All the lamps were off	The power wire not connected well or no output	Reconnect the power wire or change a power supply
	Lamp's power wire not connected well	Reconnect the power wire
	Signal terminal not connected well or the signal wires were reverse	Reconnect the signal cable
	Line is too long, for over 300m	Add terminator or amplifier
2.One or several lamps not change	Signal terminal not connected well or the signal wires were reverse	Reconnect the signal cable
	Line is too long, for over 300m	Add terminator or amplifier
3.Some color was off	Wire of this color not connected well	Reconnect the power wire
4.Wrong color was shining in change	Power wire were reverse	Reconnect the power wire
	Decoder address was wrong	Change the address (refer to the address table)
5.Irregular flicker	Signal terminal not connected well	Reconnect the signal terminal
	Line is too long, for over 300m	Add terminator or amplifier

If you still have trouble configuring it, please contact us.

Contact us:

**sirs-e**  
 SIRS Electronics Inc.  
 Phone No: (956)522-2006  
 Fax No.: (956)686-7380  
 email: [info@sirs-e.com](mailto:info@sirs-e.com)

Visit our eStore: [www.sirs-e.com](http://www.sirs-e.com)